

Working in Power

SUPREME PLUS series

on-line UPS

100 - 120 - 160 - 200 UPS

- LOCAL AREA NETWORKS (LAN)
- SERVERS
- DATA CENTERS
- INTERNET CENTERS (ISP/ASP/POP)
- INDUSTRIAL PLCS
- EMERGENCY DEVICES (LIGHTS/ALARM)
- ELECTRO-MEDICAL DEVICES
- TELECOMMUNICATIONS DEVICES
- INDUSTRIAL APPLICATIONS

SUPREME PLUS

The **SUPREME Plus** series UPS range from 100-120-160-200 kVA three-phase models and use double conversion on-line technology (VFI) with an isolation transformer on the inverter output.

The load is powered continuously by the inverter with a filtered, stabilised and regulated sinewave supply. The input and output EMI filters considerably increase the immunity of the load to mains disturbances and surges.

SUPREME Plus series is now available with 3 models to suit different applications:

- SUPREME Plus is designed with standard 6 pulse Rectifier and output power factor at 0.9
- SUPREME Plus i is designed with IGBT Rectifier & Inverter, at output power factor 0.9
- SUPREME Pro is designed IGBT Rectifier & Inverter, at unity output power factor 1

SUPREME Plus series is equipped with BATTERY PROTECTION. This helps to prolong battery life and performance.

It has:

- Cyclic charging
- Two voltage level charging
- Temperature compensation charging
- Protection against deep discharge
- Battery self test
- Compatibility with open vented lead acid and NiCad battery.



100 - 120 - 160 - 200 kVA
Front Accessible for Simplified Maintenance

Main Features:

- Easy to maintain (front access)
- Large LCD screen with graphical display
- Reliable, filtered, stabilised and regulated sinewave output (double on-line conversion technology VFI according to EN50091-3 specifications) with filters for atmospheric disturbance suppression
- High reliability: IGBT technology, full microprocessor control with no-break static and manual bypasses
- High level diagnostics: event log with 128 messages, states, measurements and alarms - available from the built-in LCD in several languages
- The UPS may be configured with the RS232 serial port (flash upgradable)
- Reduced noise levels: high frequency inverter bridge used (>16 kHz: above audible range)
- Low loss high efficiency up to 96% in On-line mode utilizing IGBT technology and up to 98% in the other operating modes: "Economy Mode", Smart Active Mode, and Standby/Off Mode.
 - Economy Mode: uses Line Interactive (VI) technology to power less critical loads from the mains supply for certain periods. The function can be set from the front panel keypad or remotely using software
- **SUPREME Plus i** and **SUPREME Pro** achieved entirely with IGBT and with special DSP controlled IGBT Rectifier. Thus guarantees maximum performance and high quality power for any IT and industrial load
- **SUPREME Plus i** and **SUPREME Pro** eliminates total input current harmonic distortion (THDi) to < 3% and improves p.f close to unity
- **SUPREME Plus** CLEAN version achieve THDi < 5%

SUPREME PLUS

Ease of Installation and Simplified Maintenance

SUPREME Plus UPS occupies only 800 x 800 (mm) whereas high performance and features SUPREME Plus i has space saving up to 30% (120KVA) as compared to SUPREME Plus 12 PCN. It can be positioned against the wall, thanks to the upward ventilation.

Access for maintenance is entirely from the front of the unit. Power and electronic components are easily accessible from the front for maintenance and repair work. This particular feature means that the MTTR (Mean Time to Repair) is typically less than 30 minutes.

A large amount of maintenance information is available from the front large screen LCD panel. In addition, system operating parameters are software configurable via a local PC to allow new functions to be added or adjustments made to operating specifications.



SUPREME Plus series provides maximum protection for vital 'mission critical' networks, medical and health care, security (electromedical) and industrial applications thanks to its outstanding mechanical and electrical design.

- Maximum flexibility allow parallel up to 8 units of identical UPS (N+1) : Multiple paralleled UPS's can be configured for common coupling of battery bank(s), thus maximising battery availability. UPS Group Synchroniser (UGS) and Parallel System Joiner (PSJ) are also available
- High level battery reliability:
 - Automatic battery test
 - Recharge compensated for temperature
 - Battery care. Battery life span can be increased approximately by 20% more
- Emergency operation: the UPS can be set to operate only when the mains fails (for emergency lighting)
- Back feed protection: to avoid energy feeding back into the mains supply
- By pass may be deactivated to allow operation as a frequency converter (at 50 or 60 Hz), or as stabiliser

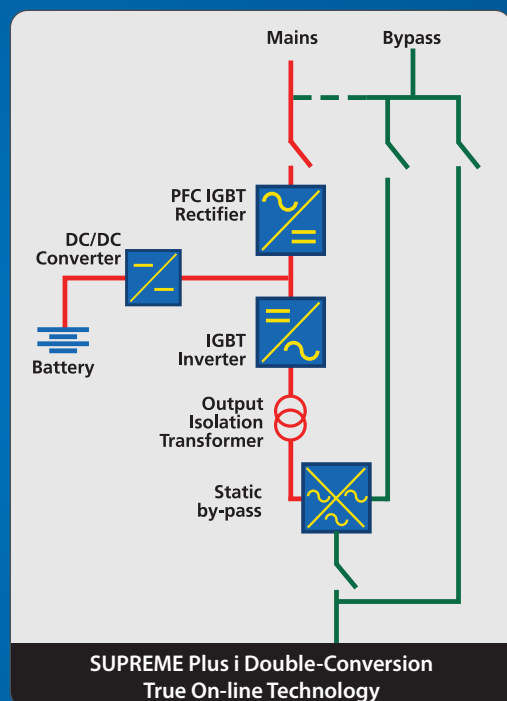

SUPREME PLUS

Optional Product for Better Flexibility.

SUPREME Plus is suitable for application of all types, from IT to the most demanding industrial applications.

Thanks to the broad offer of accessories and options, complex configurations and architectures can be produced, guaranteeing a maximum availability of power supply for the most critical loads.

Flexible Configuration

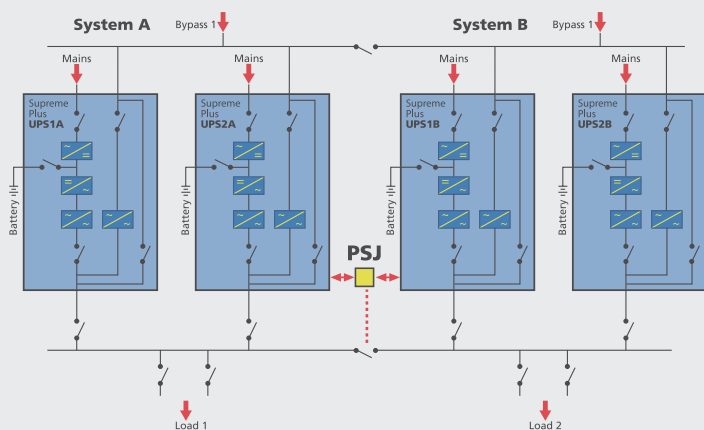

Distribution Redundancy: PSJ

The Parallel Systems Joiner (PSJ) enables the connection of two UPS groups operating in parallel configuration through a power coupling switch.

The Slave Group is permanently synchronised to the Master Group. Should one of the UPS in one of the parallel groups fail, the PSJ will automatically connect the remaining UPS to the other group.

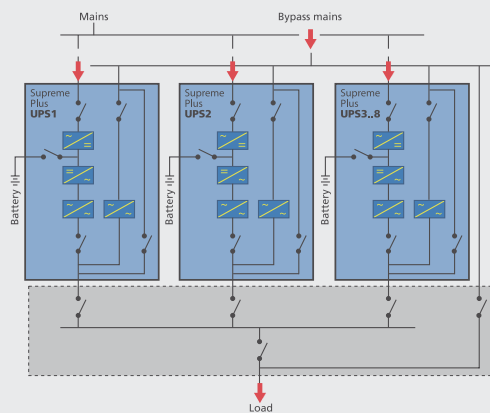

UPS Redundancy: Parallel

Parallel up to 8 UPS

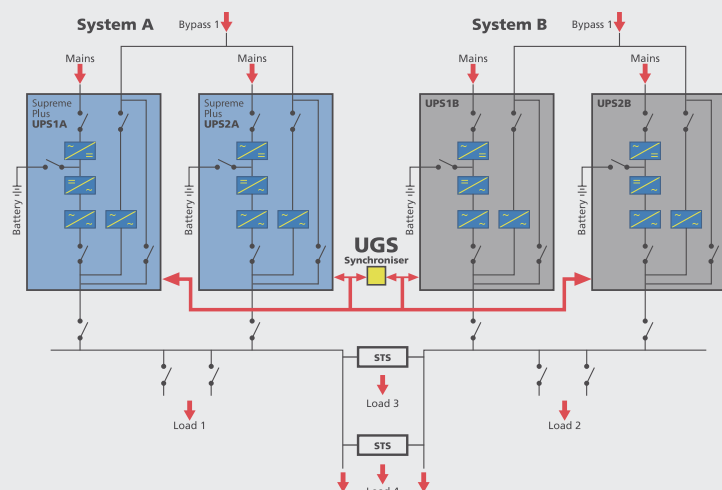

Distribution Redundancy: UGS

UPS Group Synchroniser (UGS) ensures 2 or more UPS parallel groups remain synchronised even during a mains supply failure.

The UGS also enables SUPREME Plus to be synchronised with an independent power source and even with different rating.



DETAILED UPS PARAMETER DISPLAY

UPS Monitoring Software provides all the information required for first level diagnostics

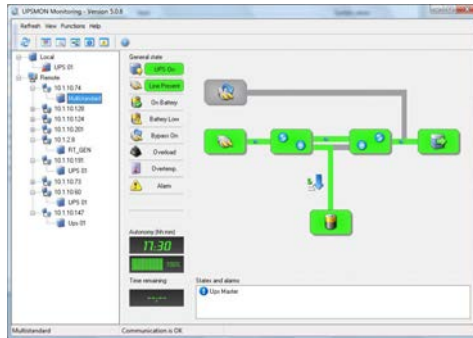

BLOCK AND FUNCTIONAL DIAGRAMS

UPS Monitoring Software also displays the UPS in block format providing the user with information regarding operating status

Direct Connection with Ethernet Network

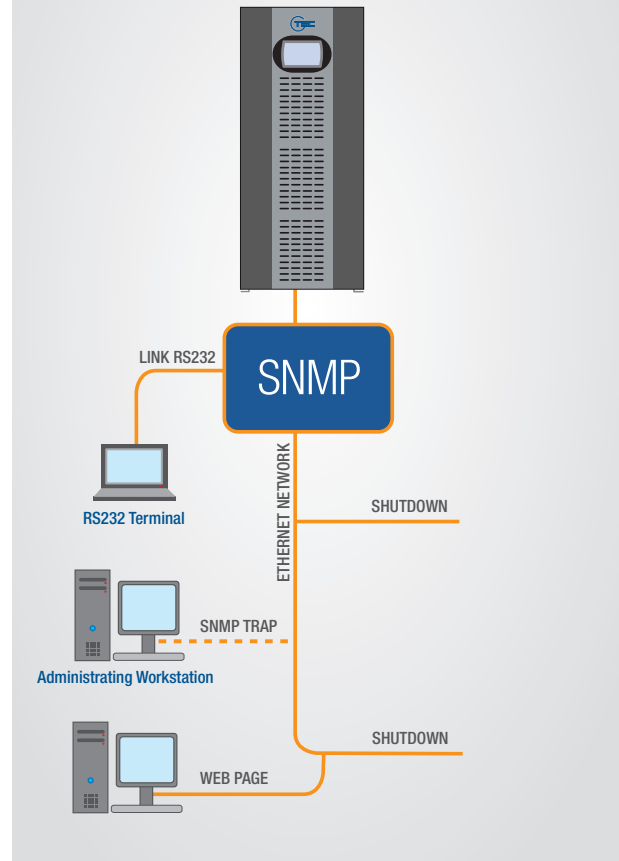

COMMUNICATION AND POWER MANAGEMENT SOLUTIONS

SUPREME Plus series provide solutions for remote monitoring and power management.

With optional SNMP card and other GTEC's peripherals, UPS can be easily integrated into any medium and large-size Data Center; UPS status can be monitored by ModBus TCP/IP; Profibus DP Network; BACnet/ IP and GSM/WIFT ready by means of customized RTG100 dongle.

UPS Monitoring Software supports the following operating systems:

- Microsoft Windows 2000, Xp, 2003
- Microsoft Vista x86 and x86_64
- Microsoft 2008, 2012 x86 and x86_64
- Microsoft 7, 8 x86 and x86_64
- Novell NetWare 3.x, 4.x, 5.x, 6
- Mac OS X 10.x.x
- Linux kernel 2.4.x and 2.6.x
- VMware ESX 4.x (vSphere)
- VMware ESXi 4.x 5.x

Full version license software supports:

- IBM AIX on RS6000 PowerPC
- HP UNIX
- SUN Solaris INTEL
- SUN Solaris SPARC
- SCO OpenServer 5
- SCO UnixWare
- Silicon Graphics IRIX
- DEC UNIX
- Compaq Tru64 UNIX
- Digital UNIX
- BSD UNIX
- NCR Unix
- FreeBSD UNIX
- Open VMS

- Compatible with TELEGUARD for remote maintenancet
- Double RS232 serial port
- Network adapter slot for SNMP agent
- EPO (Emergency Power Off) shut down input contact
- Remote control panel (optional)

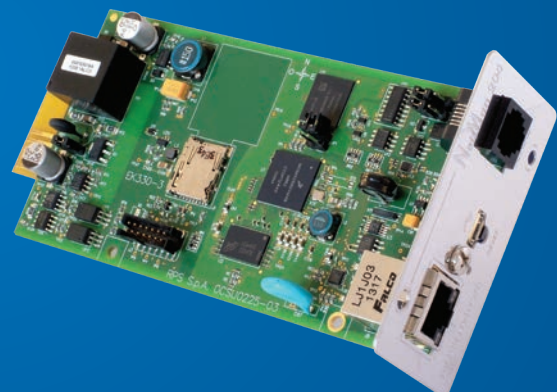

SNMP NetMan 204 card allows management of UPS across LAN using any of the main network communication protocols: TCP/IP; ModBus TCP/IP; Profibus DP and BACnet/IP

TECHNICAL **ASSISTANCE** SERVICE

UPService, our technical assistance facility uses highly trained engineers to provide a reliable and competent technical support and after-sales service.

UPService can provide customers with:

- A dedicated CALL CENTRE for connection to the UPService organisation. UPService personnel are always available and ready to provide advice and assistance regarding UPS installation, maintenance, fault finding and repair.
- **FAST & READY** A fast repair on site is guaranteed through the use of state-of-the-art UPS technology and the professionalism of the UPService personnel and Authorised Assistance Centres. UPService guarantees that failed parts are replaced with original ones, tested and updated in order to maintain the safety, reliability and operating characteristics of the UPS.
- **COMMISSIONING AND START-UP** UPService can provide assistance during commissioning and startup of the UPS equipment on-site with additional training during handover to site personnel. UPService engineers can also verify site suitability, analyse and advise on potential problems, and disconnect and relocate equipment. UPService recommend that all hardwired installations are commissioned by UPService engineers.
- **MAINTENANCE CONTRACTS** can be provided by UPService to minimise response times and repair costs. Contracts range from periodic inspections to comprehensive cover including labour and materials.
- UPService organises regular **TECHNICAL TRAINING COURSES** for UPS operators and installers.

TECHNICAL **ASSISTANCE** SERVICE



SUPREME PLUS

Technical Specification								
Models	SUPREME Plus 100 & 100i	SUPREME Pro 100	SUPREME Plus 120 & 120i	SUPREME Pro 120	SUPREME Plus 160 & 160i	SUPREME Pro 160	SUPREME Plus 200 & 200i	SUPREME Pro 200
Power Rating (kVA)	100kVA		120kVA		160kVA		200kVA	
INPUT								
Nominal Voltage	380 - 400 -415 Vac three phase							
Voltage Tolerance	+20%, -25% (SUPREME Plus) 360V - 480V for full load / 320V - 480V for 85% load / 280V - 480V from 75% load 240V - 480V from 65% load (SUPREME Plus i & SUPREME Pro)							
Frequency	45 - 65 Hz							
Power Factor	>0.99 for SUPREME Plus i and SUPREME Pro / 0.9 to 0.96 for SUPREME Plus depending on options							
Current Distortion	<3% for SUPREME Plus i and SUPREME Pro / <5% for SUPREME Plus clean version							
Soft Start	0 to 120s selectable							
Standard Fittings	Back Feed Protection; selectable bypass line							
BATTERY								
Type	Vented acid/ VRLA AGM/ GEL/ NiCd							
Residual Ripple on Voltage	<1%							
Temperature Compensation (V/°C)	-0.11%							
OUTPUT								
Active Power at pf1 (kW)	90	100	108	120	144	160	180	200
Nominal Voltage	380 - 400V - 415V AC 3 phase + N							
Static Stability	±1%							
Dynamic Stability	±5% in 20msec to class 1 of EN62040-3							
Voltage Distortion with Linear Load	<1%							
Voltage Distortion with Distorting Load	<3% (according to IEC62040-3)							
Frequency with Mains Present	50 to 60Hz auto sensing with ±2% as default (selectable from ±1% to ±5%)							
Frequency without Mains Present	±5%							
Waveform	Sinusoidal							
Crest Factor	3:1							
Overload	110% for 60'; 125% for 10'; 150% for 1'							
ENVIRONMENTAL								
Remote Reports	Voltage-free contacts							
Remote Commands	EPO and bypass							
Communication	Double RS232 + Remote Contacts + 2 Communication Interface Slots							
Efficiency	Eco mode up to 98% (SUPREME Plus & SUPREME Plus i) / 99% (SUPREME Pro) On-line mode up to 94% (SUPREME Plus & SUPREME Plus i) / Up to 96% (SUPREME Pro)							
Relative Humidity	Up to 95% non-condensing							
Noise Level	60 to 68dBA@1m							
Operating Temperature	0°C - 40°C							
Relative Humidity	<95% non condensing							
Index of Protection	IP20							
Standards	European Directive LV 2006/95/EC, EMC 2004/108/EC Safety IEC EN 62040 - 1; EMC IEC EN 62040 - 2; Performance and Test IEC EN 62040 -3							
Classification as per IEC 62040-3	(Voltage Frequency Independent) VF1-SS-111							
PHYSICAL DATA								
Size (L x D x H) - SUPREME Plus i & SUPREME Pro	800 x 850 x 1900 (mm)				1000 x 850 x 1900 (mm)			
Size (L x D x H) - SUPREME Plus	800 x 800 x 1900 (mm)							
Size (L x D x H) - SUPREME Plus CN	1070 x 800 x 1900 (mm)							
Weight (kg) - SUPREME Plus i & SUPREME Pro	730	850	785	900	865	1015	1000	1070
Weight (kg) - SUPREME Plus	620	N.A	650	N.A	730	N.A	830	N.A
Colour	Front RAL 7035							

Option:

Communication Software & Accessories; Isolation transformer; Parallelable to 8 units

Note: UPS specification and data may subject to change for improvement without prior notice

G-Tec Asia Pacific Pte Ltd

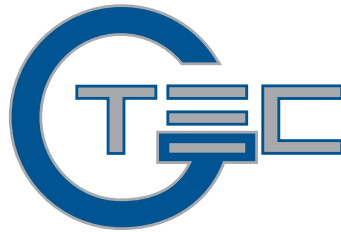

Working in Power

G-Tec Asia Pacific Pte Ltd

60 Kaki Bukit Place, #03-05, Eunos Techpark II, Singapore 415979

Tel. +65 6555.5014 - Fax +65 6555.4105

info@gtec.com.sg

www.gtec-power.com

