

Working in Power

SR10-200 series

on-line UPS

10 – 200 kVA single/single phase and three/single-phase
10, 12, 15, 20, 30, 40, 60, 80, 100, 125, 160, 200 kVA three/three-phase

- LOCAL AREA NETWORKS (LAN)
- SERVERS
- DATA CENTERS
- CASH REGISTERS
- TELECOMMUNICATION DEVICES
- E-BUSINESS (SERVERS FARMS, ISP/ASP/POP)
- INDUSTRIAL PLCS
- ELECTRO-MEDICAL DEVICES
- EMERGENCY DEVICES (LIGHTS/ALARMS)

SR10-200 series

SR10-200 is ideal for the protection of critical information and telecommunications networks which cannot run the risk of being powered from a poor quality electrical supply.

The SR10-200 series is available in 10-12-15-20 kVA three-phase and single-phase input and single-phase output models, and 10-12-15-20-30-40-60-80-100-125-160-200 kVA three-phase input and output models, with double conversion on-line technology according to the VFI-SS-111 classification, as defined by the IEC EN 62040-3 standard.

SR10-200 has been designed and manufactured using state-of-the-art technologies in order to deliver maximum protection for critical users, a zero impact on the mains power supply and a high operating efficiency.

The high level of flexibility at the design stage means that there is full compatibility both with three-phase power and with single-phase sources, thus eliminating any critical factors in the connection between UPS and system.

ZERO IMPACT SOURCE

The superior technology of a SR10-200 allows it to be used where the site mains power supply is limited in capacity, or has an on-site generator and/or loads that generate current harmonic problems. SR10-200 is designed to have a zero-impact on its upstream power supply (mains or generator).

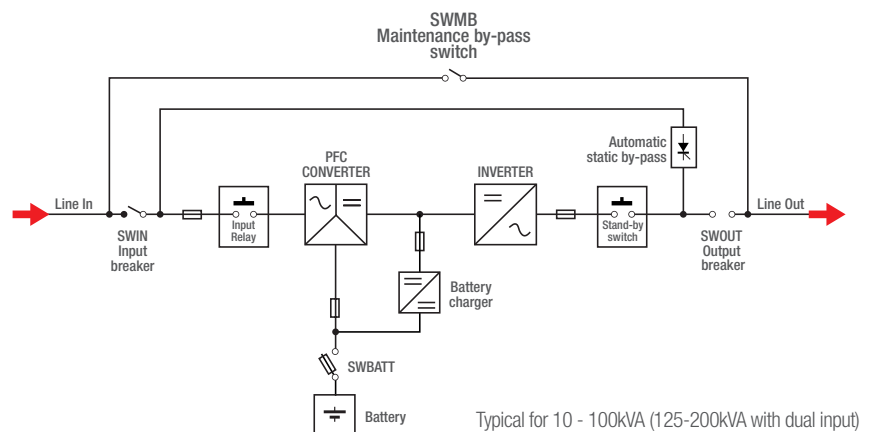

Main Features:

- Reliable, filtered, stabilised and regulated sine wave output (double on-line conversion technology VFI according to EN50091-3 standard) with filters for atmospheric disturbance suppression
- High reliability: IGBT Technology in rectifier and inverter, high frequency PWM, transformerless, fully digital control with microprocessor, no break static and manual transferring
- Cleaned source: power factor correction for unitary power factor and very low input THDI%
- First class in efficiency: high operation efficiency up to 96,5% in normal mode, up to 99% in eco mode operation
- Low noise levels: the high frequency PWM for rectifier and inverter allows very low audible noise
- Flexibility: SR10-200 can be set for several configuration as normal mode, smart mode and stand by off
- Maximum reliability: SR10-200 can work in parallel up to 6 units. The UPS continues to operate in parallel even if one of the communication cables is disconnected
- Battery care system: SR10-200 is suitable for use with sealed VRLA, AGM, GEL or open-vented lead acid batteries, Ni-Cd batteries
- Temperature voltage compensation
- Deep discharging controlled by microprocessor with load and main levels (sharing power mode suitable within -40% V_{in})
- High power availability: the output factor 0,9 providing up to 15% more active power than a traditional UPS and more load expansion
- Low management cost: the transformer less technology allows the lowest footprint in this category. The SR10-200 design allows front, top, and sides access

SR10-200 series

Cost Saving in Efficiency

SR10-200 is the first class in cost saving due to efficiency up to 96.5% providing a 50% saving in energy usage per annum compared to traditional UPS products (92% standard). This exceptional performance can lead to a full initial investment recovery within three years.

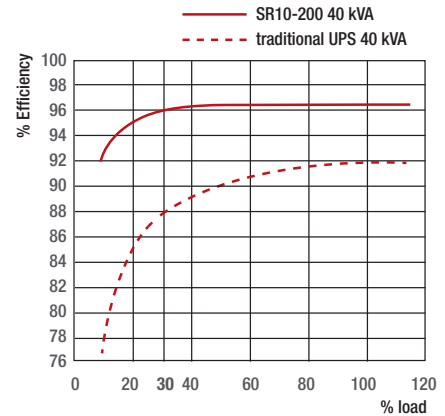

SR10-200 40 kVA

Efficiency at 75% rated load 96%

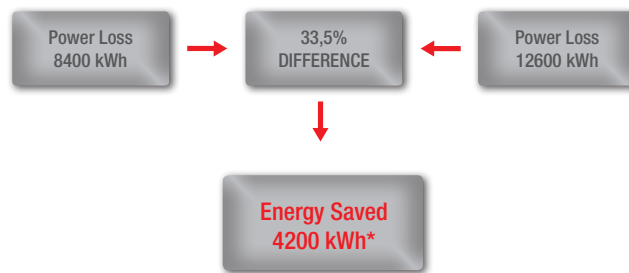

* for standard utility contract at 0,15 €/kWh that means 630 € saved per year.

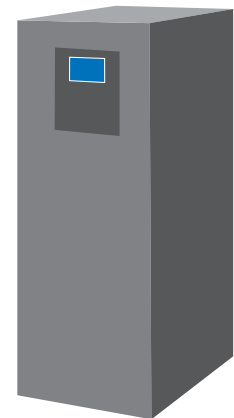

STANDARD UPS 40 kVA

Efficiency at 75% rated load 88%

UPS Front Panel:

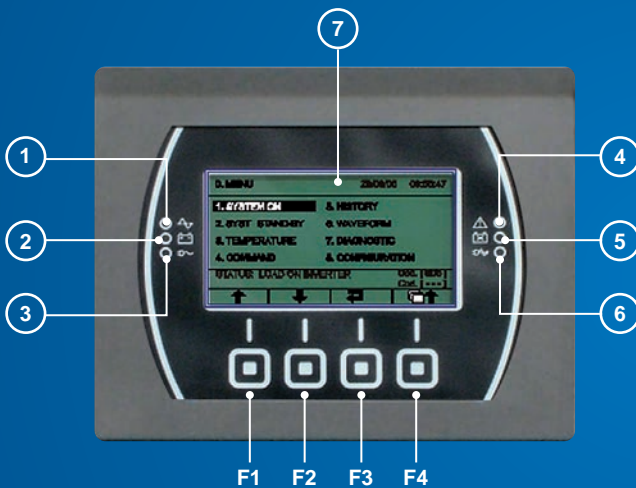

Menu

1. LED for mains operation
2. LED for battery operation
3. LED for load on bypass
4. LED for stand-by/alarm
5. LED for replacing batteries
6. LED for ECO mode
7. Graphical Display

F1, F2, F3, F4 = Function Keys.

Messages are available in the following languages:
English, Italian, French, German, Spanish, Polish, Turkish,
Chinese and Russian

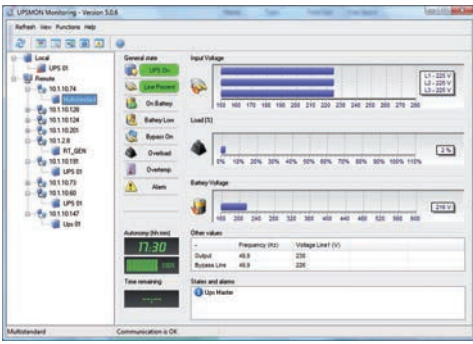

DETAILED UPS PARAMETER DISPLAY

UPS Monitoring Software provides all the information required for first level diagnostics

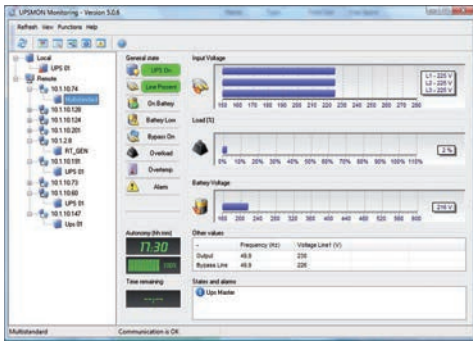

BLOCK AND FUNCTIONAL DIAGRAMS

UPS Monitoring Software also displays the UPS in block format providing the user with information regarding operating status

Direct Connection with Ethernet Network

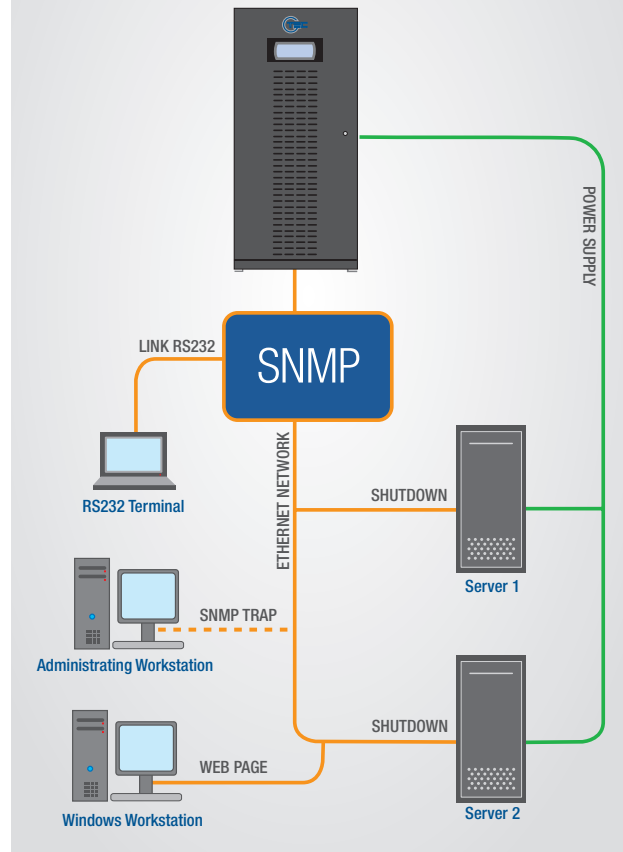

COMMUNICATION AND POWER MANAGEMENT SOLUTIONS

SR10-200 series provides solutions for remote monitoring and power management.

With optional SNMP card and other GTEC's peripherals, UPS can be easily integrated into any medium and large-size Data Center; UPS status can be monitored by ModBus TCP/IP; Profibus DP Network; BACnet/ IP and GSM/WIFT ready by means of customized RTG100 dongle.

- SR10-200 Plus is equipped with a graphic display that provides information, measures, states and alarms regarding the UPS in 9 different languages
- Advanced, multi-platform communication for all operating systems and network environments:

UPS Monitoring Software supports the following operating systems:

- Microsoft Windows 2000, Xp, 2003
- Microsoft Vista x86 and x86_64
- Microsoft 2008, 2012 x86 and x86_64
- Microsoft 7, 8 x86 and x86_64
- Novell NetWare 3.x, 4.x, 5.x, 6
- Mac OS X 10.x.x
- Linux kernel 2.4.x and 2.6.x
- VMware ESX 4.x (vSphere)
- VMware ESXi 4.x 5.x

Full version license software supports:

- IBM AIX on RS6000 PowerPC
- HP UNIX
- SUN Solaris INTEL
- SUN Solaris SPARC
- SCO OpenServer 5
- SCO UnixWare
- Silicon Graphics IRIX
- DEC UNIX
- Compaq Tru64 UNIX
- Digital UNIX
- BSD UNIX
- NCR Unix
- FreeBSD UNIX
- Open VMS

- 3 slots for the installation of optional communication accessories such as network adapters and volt-free contacts
- REPO (Remote Emergency Power Off) with which to power down the UPS through a remote emergency pushbutton
- Input for connection of the auxiliary contact of an external manual bypass
- Input for synchronisation from an external source
- Graphic mimic panel display for remote connection

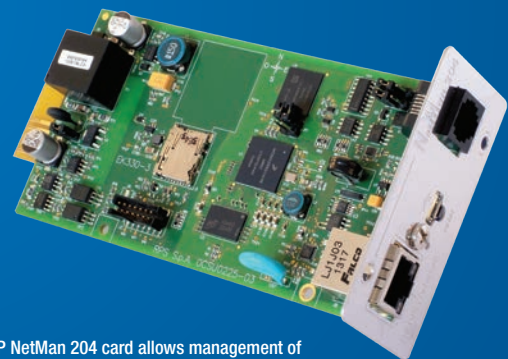

SNMP NetMan 204 card allows management of UPS across LAN using any of the main network communication protocols: TCP/IP; ModBus TCP/IP; ProfiBus DP and BACnet/IP

TECHNICAL **ASSISTANCE** SERVICE

UPService, our technical assistance facility uses highly trained engineers to provide a reliable and competent technical support and after-sales service.

UPService can provide customers with:

- A dedicated CALL CENTRE for connection to the UPService organisation. UPService personnel are always available and ready to provide advice and assistance regarding UPS installation, maintenance, fault finding and repair.
- **FAST & READY** A fast repair on site is guaranteed through the use of state-of-the-art UPS technology and the professionalism of the UPService personnel and Authorised Assistance Centres. UPService guarantees that failed parts are replaced with original ones, tested and updated in order to maintain the safety, reliability and operating characteristics of the UPS.
- **COMMISSIONING AND START-UP** UPService can provide assistance during commissioning and startup of the UPS equipment on-site with additional training during handover to site personnel. UPService engineers can also verify site suitability, analyse and advise on potential problems, and disconnect and relocate equipment. UPService recommend that all hardwired installations are commissioned by UPService engineers.
- **MAINTENANCE CONTRACTS** can be provided by UPService to minimise response times and repair costs. Contracts range from periodic inspections to comprehensive cover including labour and materials.
- UPService organises regular **TECHNICAL TRAINING COURSES** for UPS operators and installers.

TECHNICAL **ASSISTANCE** SERVICE



SR10-200 series

Technical Specification				
Three/Single phase Model	SR10M	SR12M	SR15M	SR20M
INPUT				
Rated voltage	380-400-415 Vac three-phase with Neutral / 220-230-240 single-phase			
Voltage tolerance	240V - 480V (3 Phase) / 140V - 276V (1 Phase)			
Rated frequency	50/60 Hz			
Frequency tolerance	40 ÷ 72 Hz			
Power factor at full load	0.99			
Current distortion	THDi ≤ 3%			
BY PASS				
Rated voltage	220-230-240 Vac			
Number of phases	1 phase			
Voltage tolerance	180 ÷ 264 V (selectable)			
Rated frequency	50/60 Hz (selectable)			
Frequency tolerance	± 5% (selectable)			
OUTPUT				
Rated power (kVA)	10	12	15	20
Active power (kW)	9	10.8	13.5	18
Output power factor	0.9			
Number of phases	1 phase			
Rated voltage (V)	220-230-240 Vac (selectable)			
Static variation	± 1%			
Dynamic variation	± 3%, EN62040-3 class performance 1 distorting load			
Crest factor (I _{peak} /I _{rms})	3: 1			
Voltage distortion (EN62040-3)	≤ 1% with linear load / ≤ 3% with non-linear load			
Frequency	50/60 Hz			
Frequency stability on battery mode	± 0.01%			
Overload at PF 0.9	110% for 10 minutes, 133% for 1 minute, 150% for 5 seconds			
BATTERIES				
Type	VRLA AGM/GEL; Ni-Cd; WET TYPE			
Recharge time	6 h			
ENVIRONMENTAL				
Weight without internal batteries (Kg)	105	110	115	120
Dimensions (LxDxH) (mm)	440 x 850 x 1320			
Communication	DOUBLE RS232/C - SNMP Agent - MODBUS - PROFIBUS			
Operating temperature	0°C / +40°C			
Relative humidity	90% non condensing			
Colour	Dark Grey RAL 7016			
Noise (dBA @ 1m)	≤ 48		≤ 52	
Protection rating	IP20			
Efficiency Smart Mode	≥ 98% in Economy mode			
Compliance	European Directives: L V 2006/95/CE Low voltage directive EMC 2004/108/EC Electromagnetic compatibility directive Standards: Safety IEC EN 62040-1; EMC IEC EN 62040-2 C2 Classification according to IEC 62040-3 (Voltage Frequency Independent) VFI - SS - 111			

SR10-200 series

Technical Specification												
Models	SR10T	SR12T	SR15T	SR20T	SR30T	SR40T	SR60T	SR80T	SR100T	SR125T	SR160T	SR200T
INPUT												
Rated voltage	380-400-415 Vac three-phase with Neutral											
Voltage tolerance	240V - 480V (3 Phase)											
Rated frequency	50/60 Hz											
Frequency tolerance	40 ÷ 72 Hz											
Power factor at full load	0.99											
Current distortion at full load	≤ 3%						2.5%					
BY PASS												
Rated voltage	380-400-415 Vac three-phase with Neutral											
Number of phases	3 phase + N											
Voltage tolerance	180 ÷ 264 V (selectable)											
Rated frequency	50/60 Hz (selectable)											
Frequency tolerance	± 5% (selectable, adjustable from 0.25% to 10%)											
Frequency stability on battery mode	± 0.01%											
Overload at pF 0.8	≤ 110%infinite; >110% to ≤ 133% for 60 mins; >133% to ≤ 150% for 10mins; >150% to ≤ 200% for 3sec; >200% for 2 sec										≤ 110% infinite; >110% to ≤ 125% for 60 mins; >125% to ≤ 150% for 10mins; >150% for 60 sec	
OUTPUT												
Rated power (kVA)	10	12	15	20	30	40	60	80	100	125	160	200
Active power (kW)	9	10.8	13.5	18	27	36	54	72	90	112.5	160	200
Output power factor	0.9											1
Number of phases	3 phase + N											
Rated voltage (V)	380-400-415 Vac (selectable)											
Static variation	± 1%						± 0.5%					
Dynamic variation	± 3%, EN62040-3 class performance 1 distorting load											
Crest factor (Ipeak/Irms)	3: 1											
Voltage Distortion with linear load	≤ 1%								≤ 1%	≤ 1%	≤ 0.5%	
Voltage Distortion with non-linear load	≤ 3%								≤ 3.5%	≤ 3%	≤ 3%	
Frequency	50/60 Hz											
Frequency stability on battery mode	0.01%											
Overload at PF 0.9	103% infinite, 110% for 10 mins, 133% for 1 minute, 150% for 5 seconds, 200% for 0.5 seconds										103% infinite ; 110% for 60 mins; 125% for 10mins; 150% for 60 sec	
Overload at PF 0.8	110% continuous, 125% for 10 minutes, 150% for 60 seconds											
BATTERIES												
Type	VRLAAGM/GEL; Ni-Cd; WET TYPE											
Recharge time	6 h											
ENVIRONMENTAL												
Weight without internal batteries (Kg)	105	110	115	120	135	145	190	200	220	250	450	460
Dimensions (LxDxH) (mm)	440 x 850 x 1320						500 x 850 x 1600			650 x 830 x 1600	640 x 1050 x 1900	
Communication	DOUBLE RS232/C - SNMP Agent - MODBUS - PROFIBUS											
Operating temperature	0°C / + 40°C											
Relative humidity	90% non condensing											
Colour	Dark Grey RAL 7016											
Noise	≤ 48		≤ 52		≤ 48		≤ 63				≤ 68	≤ 70
Protection rating	IP20											
Efficiency Smart Mode	up to 99%											
Compliance	European Directives: L V 2006/95/CE Low voltage directive EMC 2004/108/EC Electromagnetic compatibility directive Standards: Safety IEC EN 62040-1; EMC IEC EN 62040-2 C2 Classification according to IEC 62040-3 (Voltage Frequency Independent) VFI - SS - 111											

NOTE: UPS specification and data may be subjected to change for improvement without prior notice

G-Tec Asia Pacific Pte Ltd

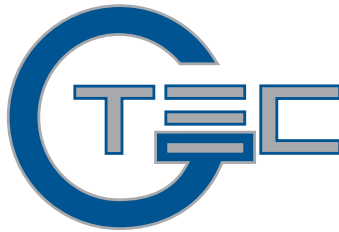

Working in Power

G-Tec Asia Pacific Pte Ltd

60 Kaki Bukit Place, #03-05, Eunos Techpark II, Singapore 415979

Tel. +65 6555.5014 - Fax +65 6555.4105

info@gtec.com.sg

www.gtec-power.com

